

VOLTAGE		
Field selectable to match power source of 12, 16, or 24 VAC/VDC.		
CURRENT DRAW/AMPS		
Volts	AC	DC
12	.163	.440
16	.228	.458*
24	.084	.230

\*Requires 16 VDC adapter (P/N VA 7400-16VDC)

**Opens electrically under 35lbs. of preload!**

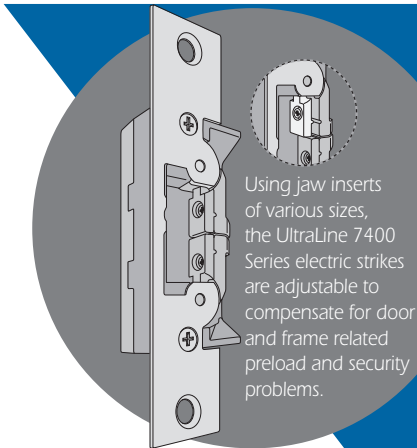

**Listed for Burglary Resistance (UL1034)**

### Case

Approx. 1" x 3-3/8" x 1-1/16" deep. Zinc-aluminum alloy.

### Strike Lip

Basic 7400 strike has lip of proper length for 1-3/4" thick door that closes flush with jamb edge. Where door thickness or jamb shape differs from this standard relationship, lip extension kits available. (Not available on 7401.)

### Fail-Safe/Fail-Secure

Field selectable at time of installation.

### Strike Opening

5/8" Adjustable x 1-7/16" x 1/2" deep. Bolt retainer jaw is stainless steel. Strike accepts bolt of any Adams Rite 4500/4700/4900 Series deadlatch or cylindrical latches.

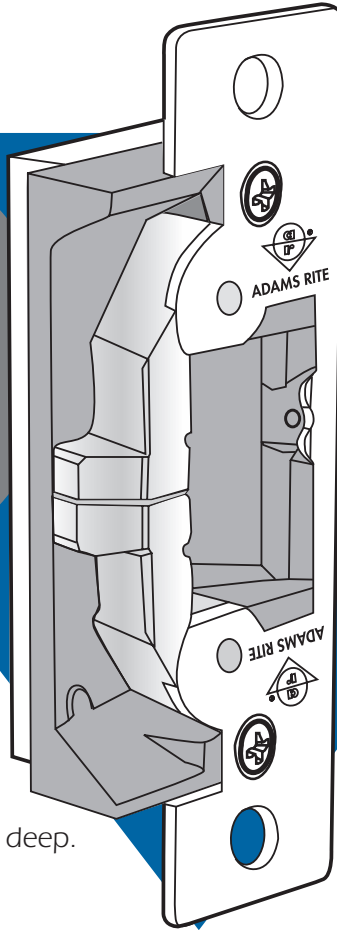

# ULTRA LINE

## 7400, 7401

ANSI/BHMA Type EO9321 (Grade 1)

### LATCH TYPE

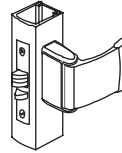

Adams Rite or Cylindrical Latches with 1/2" to 5/8" Projection

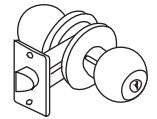

### DOOR FRAME TYPE

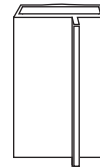

**7400**  
Aluminum Jamb

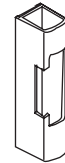

**7401**  
Aluminum Stiles

### Faceplate

Measures 1-1/4" x 4-7/8". 7400 has flat faceplate; 7401 is radiused to match nose on inactive leaf in a pair of aluminum stile glass doors. Available in a wide range of architectural finishes.

### Function

Remote electrical control of any door equipped with an Adams Rite Series 4500/4700/4900 (or similar) deadlatch or "key-in-lever/cylindrical" sets. Electrical actuation unlocks strike jaw, releasing latchbolt so door can be opened without operating latch itself. Extremely compact mechanism fits into aluminum jamb (or opposing door) sections as shallow as 1-1/16". Direct replacement for 7500/7800/7000/7100 series.

This non-handed strike features an ultra-compact design and an adjustable stainless steel split-jaw with over 2400lbs. of holding force. The strike releases electrically with up to 35lbs. of door "preload" (pressure exerted on doors by air conditioning systems, warping or misaligned hardware which can disable common electric strikes). Single solenoid operates on 12, 16, or 24 volt AC/DC power. Strikes are equipped with a quick connect plug-in type connector.



# 7400, 7401 Electric Strikes

## DIMENSIONS

INCHES  
MILLIMETERS

Nominal, subject to tolerance extremes.

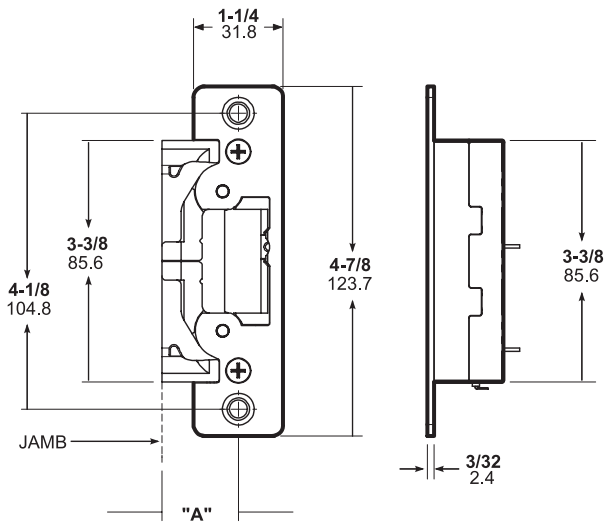
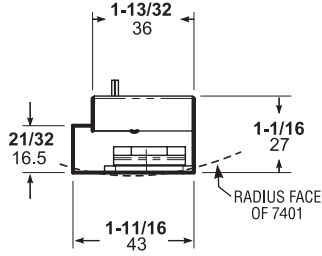

STANDARD UNIT FITS DIM "A" 1-1/16"  
MOUNTING BACKSETS FURNISHED

## HOW TO ORDER

Specify quantity and the following information.  
Order related hardware separately.

Fail-secure can be field converted to fail-safe or vice-versa.

### Specify Model

**7400** Flat  
**7401** Radius\*\*

### Options

- None
- M** Monitored
- A** Modular Pack - Body Kit\*

# 7400 M 628

### Finish

- 628** Clear Anodized
- 605** Bright Brass
- 606** Satin Brass
- 611** Bright Bronze
- 612** Satin Bronze
- 313** Dark Bronze Anodized
- 335** Black Anodized
- 629** Bright Stainless
- 630** Satin Stainless

### Ritecoat Finish (7401 only)

- 130** to match 628 Clear Anodized
- 121** to match 313 Dark Bronze Anodized
- 119** to match 335 Black Anodized

\*Modular Packing Program - match body kit with faceplate kit to complete. Use 7400A for standard jambs and 7401A for radius stile mounting. No finish designation required.

## INSTALLATION

### Jamb Preparation

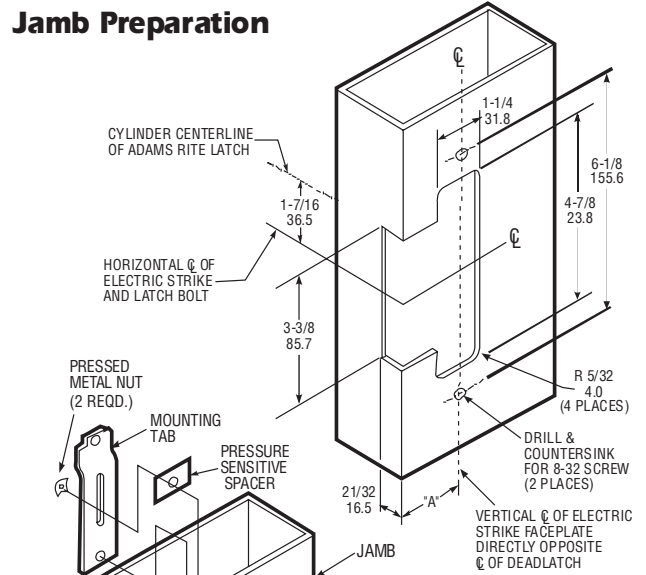

### Installation

Turn strike upside down for opposite hand.

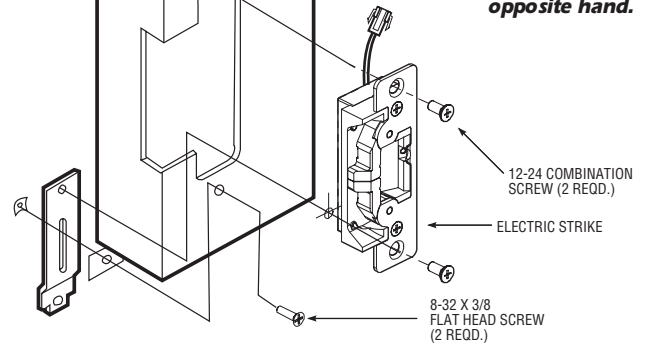

## STANDARD PACKAGE

Individually boxed with mounting screws, mounting tabs, adhesive shims to accommodate jamb or stile extrusion thickness greater or less than nominal 1/8", an adjustable jaw shim pack and two plug-in voltage adapters for 12/16/24 VAC and 12/24 VDC.

## OPTIONS

**Monitoring** - Two internally mounted switches (Form "C") to indicate when the latchbolt is engaged in the strike jaws and a locked/unlocked solenoid status. See page A-16 for more details.

**Power Sources** - 4605/4606 Transformer, 4603 Rectifier, and PS-1 Power Supply. See page A-16 for more details.

**Lip Extension Kits** - See page AC-16 for a complete list.

**Modular Packaging** - Consult factory or sales representative for details.

**ELX ElectroLynx™ Adapter** - Connects Adams Rite electrified products to ElectroLynx system.

**16 VDC Adapter** - VA7400-16VDC required when using 16VDC power.